



5/2-directional valve, Series HF03-LG

- For series : HF03-LG, CL03
- Qn = 850 l/min
- Pilot valve width : 16 mm
- Plate connection
- Manual override : with detent
- single solenoid Double solenoid
- Pilot : external, internal



Version	Spool valve, positive overlapping
Activation	Electrically
Pilot	external, internal
Sealing principle	Soft sealing
Blocking principle	Single base plate principle
Working pressure min./max.	-0,9 ... 10 bar
Control pressure min./max.	2,5 ... 10 bar
Ambient temperature min./max.	0 ... 50 °C
Medium temperature min./max.	0 ... 50 °C
Medium	Compressed air
Max. particle size	5 µm
Oil content of compressed air	0 ... 5 mg/m ³
Nominal flow Qn	850 l/min
Pilot control exhaust	With collective pilot air exhaust
Protection class with connection	IP65
Protective circuit	Z-diode
Reverse polarity protection	Protected against polarity reversal
LED status display	Yellow
Duty cycle	100 %
mounting screws	cross recessed DIN EN ISO 4757-Z1
Mounting screw tightening torque	1,3 Nm
Weight	0,082 kg

Technical data

Part No.	MO	Operationalvoltage	Voltage tolerance	Power consumption
		DC	DC	DC
0820055051		24 V	-15% / +20%	0,35 W
0820055501		24 V	-15% / +20%	0,35 W
0820055001		24 V	-15% / +20%	0,35 W

Part No.	Flow conductance	Flow conductance	Typ. switch-on time	Typ. switch-off time
	b	C-value		
0820055051	0,22	2,98 l/(s*bar)	16 ms	23 ms
0820055501	0,22	2,97 l/(s*bar)	13 ms	15 ms
0820055001	0,22	2,98 l/(s*bar)	15 ms	23 ms

Nominal flow Qn at 6 bar and $\Delta p = 1$ bar, MO = Manual override

Technical information

The min. control pressure must be adhered to, since otherwise faulty switching and valve failure may result!

The pressure dew point must be at least 15 °C under ambient and medium temperature and may not exceed 3 °C .

The oil content of compressed air must remain constant during the life cycle.

Use only the approved oils from AVENTICS. Further information can be found in the "Technical information" document (available in the MediaCentre).

The pilot type (external/internal) is not implemented in the valve, but in the end plate of the valve system.

The pilot valve is UL (Underwriters Laboratories) certified.

Technical information

Material	
Housing	Polyamide, fiber-glass reinforced
Seals	Acrylonitrile butadiene rubber

Dimensions

Dimensions

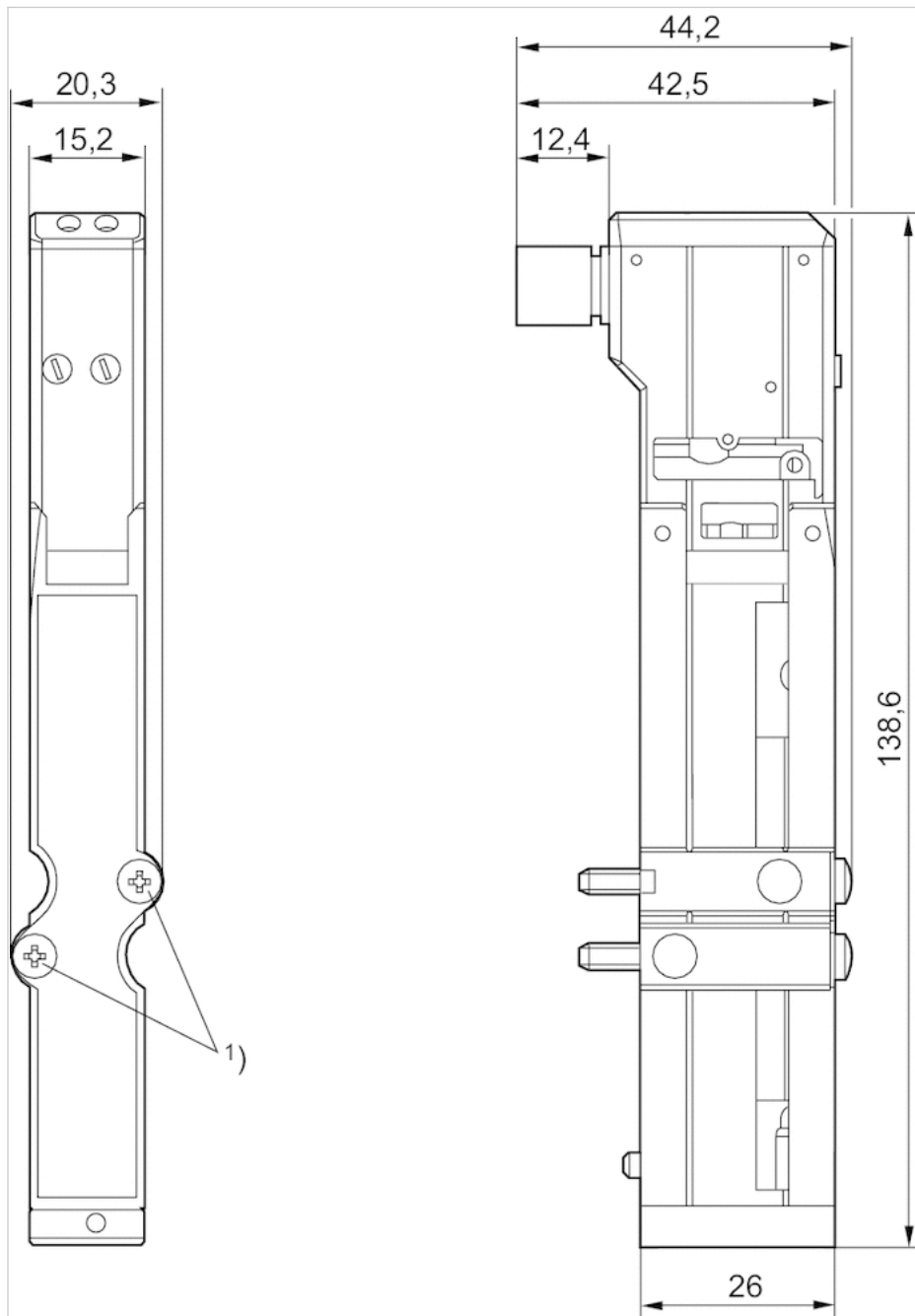

1) Mounting screw: X-slot DIN EN ISO 4757-Z1tightening torque for mounting screw [Nm]: 1.3