

2x3/2-directional valve, Series HF03-LG

- For series : HF03-LG, CL03
- $Q_n = 850$ l/min
- Pilot valve width : 16 mm
- Plate connection
- Manual override : with detent
- Pilot : external, internal



Version	Spool valve, positive overlapping
Activation	Electrically
Pilot	external, internal
Sealing principle	Soft sealing
Blocking principle	Single base plate principle
Working pressure min./max.	-0,9 ... 10 bar
Control pressure min./max.	2,5 ... 10 bar
Ambient temperature min./max.	0 ... 50 °C
Medium temperature min./max.	0 ... 50 °C
Medium	Compressed air
Max. particle size	5 µm
Nominal flow Q_n	850 l/min
Pilot control exhaust	With collective pilot air exhaust
Protection class with connection	IP65
Protective circuit	Z-diode
Reverse polarity protection	Protected against polarity reversal
LED status display	Yellow
Duty cycle	100 %
Typ. switch-on time	16 ms
Typ. switch-off time	25 ms
mounting screws	cross recessed DIN EN ISO 4757-Z1
Mounting screw tightening torque	1,3 Nm
Weight	0,082 kg

Technical data

Part No.	MO	Operationalvoltage	Voltage tolerance	
			DC	DC
0820055101	NC/NC	24 V	-15% / +20%	
0820055201	NO/NO	24 V	-15% / +20%	
0820055301	NC/NO	24 V	-15% / +20%	
0820055311	NO/NC	24 V	-15% / +20%	

Part No.	Power consumption	Flow conductance	Flow conductance
	DC	b	C-value
0820055101	0,35 W	0,22	2,97 l/(s*bar)
0820055201	0,35 W	0,22	2,97 l/(s*bar)
0820055301	0,35 W	0,22	2,97 l/(s*bar)
0820055311	0,35 W	0,22	2,97 l/(s*bar)

Nominal flow Q_n at 6 bar and $\Delta p = 1$ bar, MO = Manual override

Technical information

The min. control pressure must be adhered to, since otherwise faulty switching and valve failure may result!

The pressure dew point must be at least 15 °C under ambient and medium temperature and may not exceed 3 °C .

The oil content of compressed air must remain constant during the life cycle.

Use only the approved oils from AVENTICS. Further information can be found in the "Technical information" document (available in the MediaCentre).

The pilot type (external/internal) is not implemented in the valve, but in the end plate of the valve system.

The pilot valve is UL (Underwriters Laboratories) certified.

Technical information

Material	
Housing	Polyamide, fiber-glass reinforced
Seals	Acrylonitrile butadiene rubber

Dimensions

Dimensions

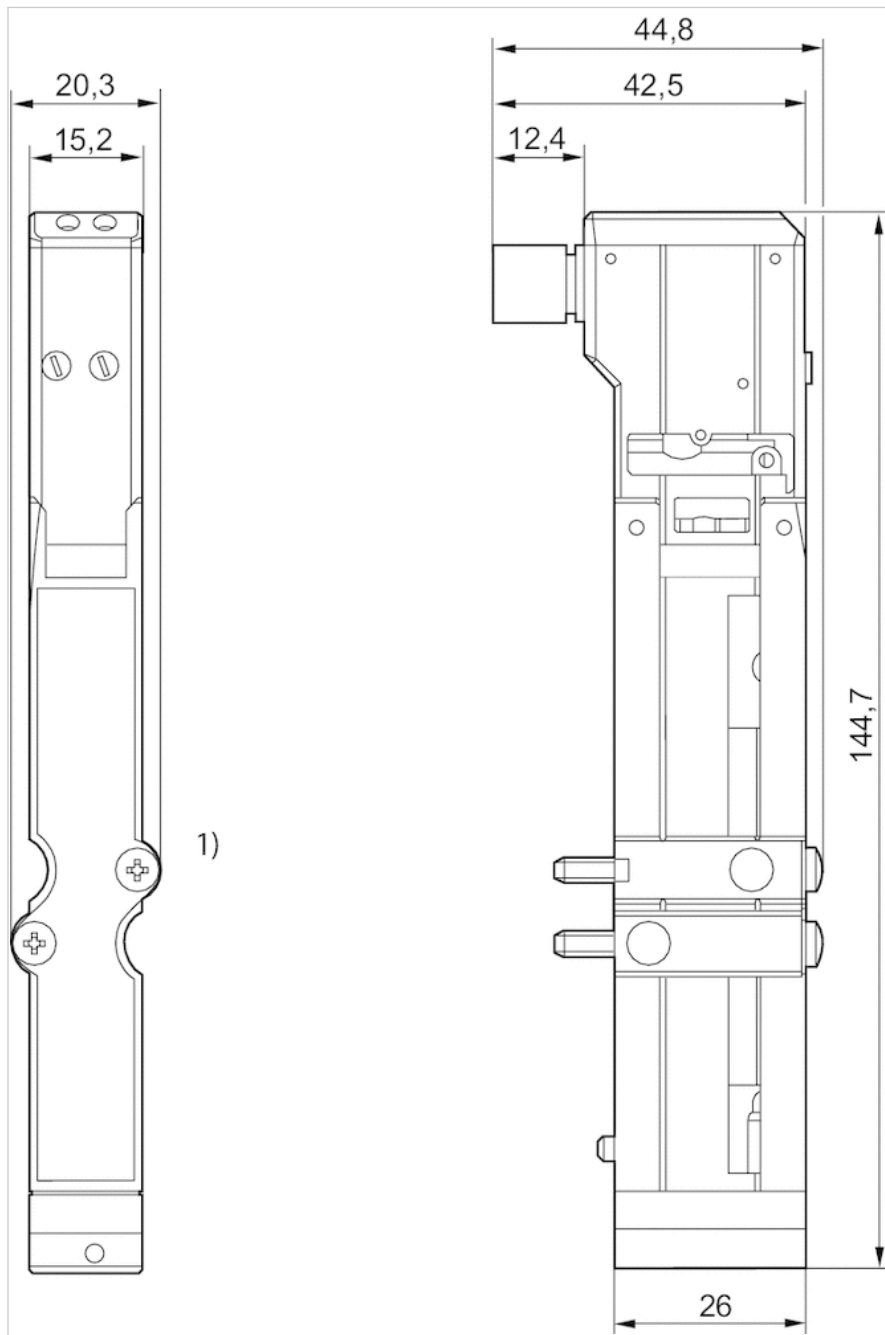

1) Mounting screw: X-slot DIN EN ISO 4757-Z1tightening torque for mounting screw [Nm]: 1.3